

Sandvik DC120

Surface Top Hammer Drills



Sandvik DC120 is a hydraulic, self-propelled drilling unit on a 4-wheel drive carrier.

Typical applications for DC120 are foundation drilling, road cutting, trenching, bolting, line drilling in dimensional stone quarries and other special drilling applications. Therefore DC120 is most often used by construction contractors, mines and quarries, and the municipal sector. Thanks to its versatility DC120 is often included in the equipment fleet of rental houses as well.

Hole Diameter:	22 - 45 mm ($\frac{7}{8}$ " - $1\frac{3}{4}$ ")
Rock Tools:	19, 22 or 25 mm ($\frac{3}{4}$ " , $\frac{7}{8}$ " or 1") rods
Rock Drill:	5,5 kW
Engine Output:	37 kW
Flushing Air:	1,2 m ³ /min, up to 8 bar
Production Capacity:	300 - 540 m ³ /8h
Total Weight	2 710 kg

STANDARD COMPONENTS

Rock drill	HEX 1, hydraulic
Chain feed	CF 100 x 32 / HEX 1, incl. one set of jaws
Rod rack	On the carrier
Boom	DB 120, articulated
Carrier	Rubber-tyred
Powerpack	Diesel driven, hydraulic pumps and on-board compressor
Hydraulic system	Open center
Control system	TA 132/120, manual
Dust collector system	DC 120, hydraulic
Working lights	4 pcs
Hydraulic jacks	4 pcs
Manuals	1 x paper copy 1 x CD-ROM (ToolMan)

THE JAWS FOR DRILL STEELS

Drill steel type	Drill steel diameter	Recommended hole diameter
Hexagonal steels	19 mm $\frac{3}{4}$ "	22 - 27 mm $\frac{7}{8}$ " - $1\frac{1}{16}$ "
Hexagonal steels	22 mm $\frac{7}{8}$ "	28 - 45 mm $1\frac{7}{64}$ " - $1\frac{3}{4}$ "
Hexagonal steels	25 mm 1"	35 - 45 mm $1\frac{3}{8}$ " - $1\frac{3}{4}$ "
MF rods	R23	33 - 45 mm $1\frac{5}{16}$ " - $1\frac{3}{4}$ "
Shank adapter/ Shank rod	R23	33 - 45 mm $1\frac{5}{16}$ " - $1\frac{3}{4}$ "
Shank rod Alpha 250	25 mm 1"	35 - 45 mm $1\frac{3}{8}$ " - $1\frac{3}{4}$ "

If several jaws selected please specify jaws assembled

SELECTION OF OPTIONS

1.	Spirit level angle indicator
2.	TIM 1402 feed angle measuring system for DC120
3.	TIM 1403 feed angle and depth measuring system for DC120
4.	Shut down of suction for water holes
5.	Water flushing kit without water pump
6.	Chain tracks
7.	Hydraulic winch
8.	Electric heater for engine
9.	Manual fuel filling pump
10.	Electric fuel filling pump
11.	Grinder Dynaset

12.	Grinder Sandvik RG100H
13.	Central lubrication system Lincoln
14.	Exhaust gas purifier
15.	Biodegradable hydraulic oil, Shell Naturelle HFE 46 or HFE 68
16.	Kit for alternative steels, each
17.	First service kit for DC120
18.	Special tools for HEX 1
19.	Security+ (Silver, Gold or Platinum)
20.	Extra manuals, price will be added according to pricing sheet

COVERAGE AREA

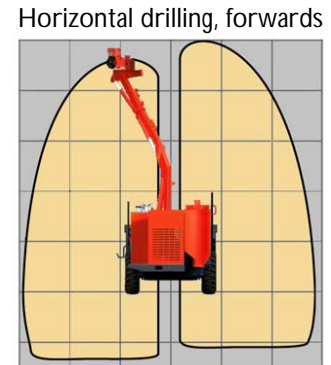
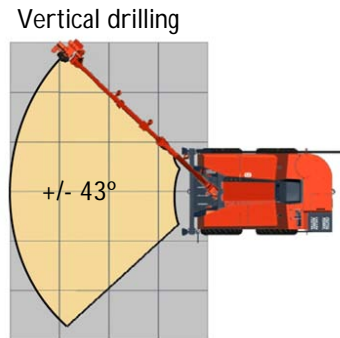
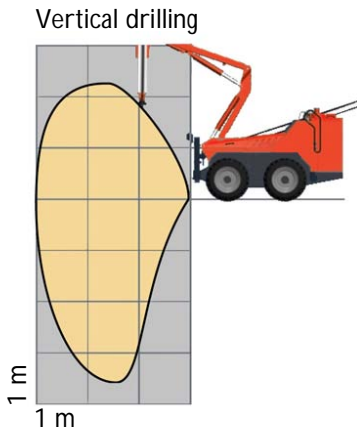

Horizontal drilling, sideways
With manual roll-over

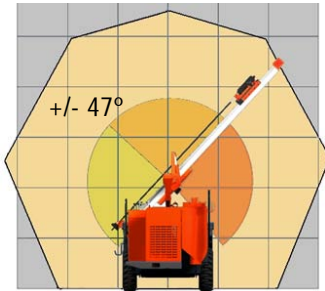

Horizontal drilling, sideways

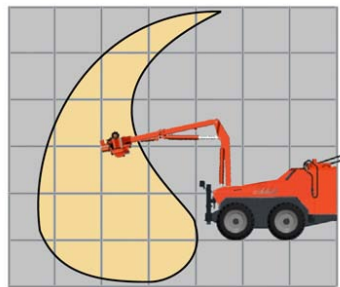

TRAMMING AND TRANSPORT DIMENSIONS

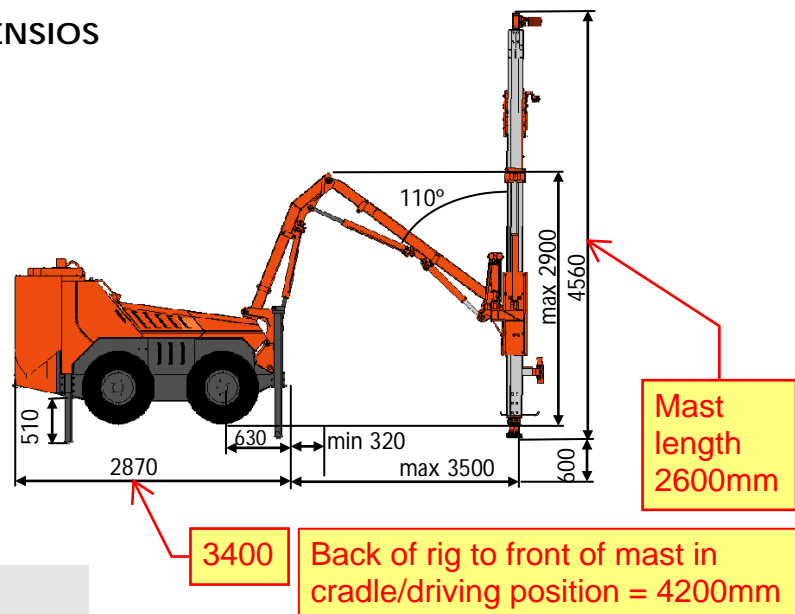
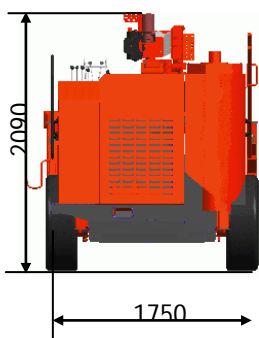

Weight (without options)	2 710 kg
Width	1.8 m
Height	2.2 m
Total length	4.5 m